

HUMIDITY SEPARATORS S25/SS (PN 16 and PN 40)



DESCRIPTION

The S25 series centrifugal separators remove moisture from steam and compressed air pipelines. Steam and compressed air pass through the separator and, as a result of centrifugal forces, impacts and swirling effects, the particles with a heavier specific gravity, such as water and oil droplets, moisture in suspension, dirt and scale are separated from the fluid.

The condensate collected at the bottom of the separator must be automatically drained by a suitable steam or compressed air trap.



MAIN FEATURES

Several possibilities of installation.

No moving parts.

Maintenance-free design.

OPTIONS: Flanged condensate connection.

USE: Steam, compressed air and other gases.

AVAILABLE

MODELS: S25/SS – stainless steel.

SIZES: DN 15 to DN 300.

CONNECTIONS: Flanged EN 1092-1 PN 16 or PN 40.
Flanged ASME B16.5 Class 150 or 300 on request.
Female threaded ISO 7 Rp or NPT on request.

INSTALLATION: Always with the condensate discharge pointing downwards.
See IMI – Installation and maintenance instructions.

CE MARKING – GROUP 2 (PED – European Directive)			
PN 16	Category	PN 40	Category
DN 15 to 25	SEP	DN 15 to 32	1 (CE marked)
DN 32 to 50	1 (CE marked)	DN 40 to 80	2 (CE marked)
DN 65 to 125	2 (CE marked)	DN 100 to 150	3 (CE marked)
DN 150 to 200	3 (CE marked)	DN 200 to 300	4 (CE marked)
DN 250 to 300	4 (CE marked)	–	–

LIMITING CONDITIONS							
FLANGED PN 16 *		FLANGED CLASS 150 **		FLANGED CLASS 300 **		FLANGED PN 40 *	
ALLOW. PRESS.	RELATED TEMP.	ALLOW. PRESS.	RELATED TEMP.	ALLOW. PRESS.	RELATED TEMP.	ALLOW. PRESS.	RELATED TEMP.
16 bar	50 °C	15,3 bar	50 °C	39,9 bar	50 °C	40 bar	50 °C
15 bar	100 °C	13,3 bar	100 °C	34,4 bar	100 °C	37,9 bar	100 °C
12,7 bar	200 °C	11,1 bar ***	200 °C	26,6 bar ***	250 °C	29,9 bar ***	250 °C
12 bar ***	250 °C	–	–	25,2 bar	300 °C	27,6 bar	300 °C

* Rating according to EN 1092-1:2018; ** According to EN 1759-1:2004; *** PMO – Maximum operating pressure for saturated steam.
Minimum operating temperature: -10 °C. Design code: AD-Merkblatt.

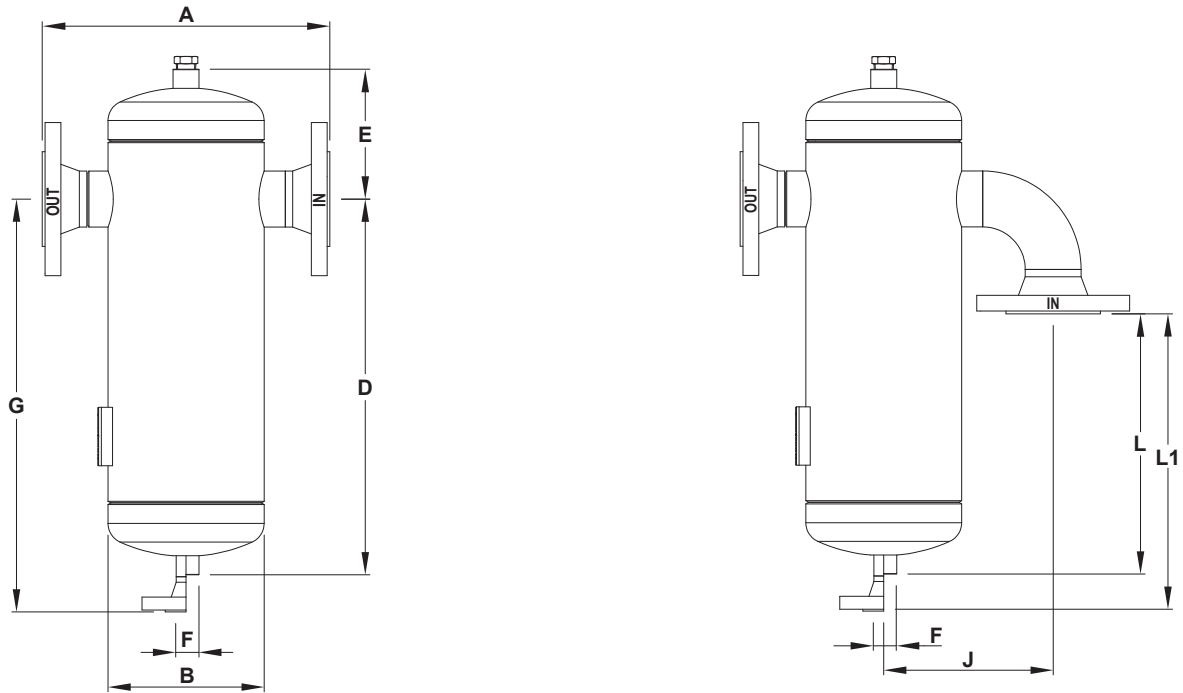

EVH – Elbow vertical inlet / horizontal outlet

APPROXIMATE DIMENSIONS (mm) *															
SIZE	PN 16									CLASS 150				VOL. (L)	WGT. (kg)
	A	B	D	E	F **	G	J	L	L1	A	G	L	L1		
DN 15	230	114	205	95	1/2"	245	115	144	184	250	255	135	185	2	5,4
DN 20	230	114	205	95	1/2"	245	115	136	176	255	255	123	173	2,5	5,8
DN 25	230	114	220	120	1/2"	260	135	142	182	262	270	126	176	3	6,8
DN 32	260	140	305	130	1/2"	345	155	194	234	290	355	200	250	5	11,4
DN 40	260	140	345	130	1/2"	385	165	243	283	294	395	226	276	5,7	12,6
DN 50	310	168	405	140	1/2"	445	190	281	321	341	455	265	315	10,5	18,4
DN 65 ***	380	219	430	160	3/4"	470	240	275	315	430	483	250	303	18,5	29,8
DN 80	400	219	482	168	3/4"	522	260	306	346	440	535	286	339	25	33,6
DN 100	470	273	548	207	3/4"	588	330	326	366	520	601	302	355	35,4	49,7
DN 125	535	324	652	241	1"	688	403	380	426	605	704	346	408	62	76
DN 150	565	356	712	292	1"	758	457	428	474	633	774	394	456	75	104
DN 200	605	406	902	312	1"	948	545	485	531	685	965	446	508	140	168,5
DN 250	720	508	1165	425	1 1/2"	1210	671	714	779	784	1227	682	764	280	318
DN 300	860	610	1197	553	1 1/2"	1262	800	662	727	933	1279	626	708	452	463

* For certified values, consult manufacturer. Volume and weight refer to EN flanged versions. Other versions may have slightly different values.
 ** As standard, in separators manufactured with EN flanges, the drain connection is female threaded ISO 7 Rp. In models with ASME flanges, this connection is female threaded NPT. Alternatively, EN 1092-1 or ASME B16.5 flanged drain connection can be supplied (ASME in the same class as main connections).
 *** Standard PN 16 DN 65 flanges are supplied with 4 holes. 8 holes, according to EN 1092, on request.
 Remarks: The top of the separator is supplied with a threaded connection, which size does not exceed the size of the drain connection. This connection is always supplied with a threaded socket. It can be used for air venting or sensing pipe connection.

APPROXIMATE DIMENSIONS (mm) *															
SIZE	PN 40									CLASS 300				VOL. (L)	WGT. (kg)
	A	B	D	E	F **	G	J	L	L1	A	G	L	L1		
DN 15	230	114	210	105	1/2"	250	115	144	184	259	264	130	182	2	6,6
DN 20	230	114	210	105	1/2"	250	115	136	176	264	264	119	173	2,5	7,4
DN 25	230	114	220	120	1/2"	260	135	142	182	274	274	120	174	3	8,5
DN 32	260	140	305	130	1/2"	345	155	194	234	303	360	215	269	5	13
DN 40	260	140	345	130	1/2"	385	165	243	283	307	399	220	274	5,7	16
DN 50	310	168	395	150	1/2"	435	190	281	321	354	450	259	313	10,5	24
DN 65	394	219	415	175	3/4"	455	240	268	308	442	472	244	301	18,5	39
DN 80	410	219	470	180	3/4"	510	260	298	338	459	527	277	334	25	44
DN 100	490	273	530	225	3/4"	570	330	313	353	530	587	293	350	35,4	75
DN 125	561	324	627	262	1"	668	403	367	379	622	690	337	401	50	114
DN 150	605	356	712	292	1"	754	457	408	427	652	776	385	449	75	131
DN 200	650	406	852	362	1"	898	545	459	478	700	920	436	500	140	264
DN 250	810	508	1165	425	1 1/2"	1235	671	679	736	815	1259	666	760	280	454
DN 300	946	610	1325	580	1 1/2"	1390	800	625	695	976	1404	597	691	489	735

* For certified values, consult manufacturer. Volume and weight refer to EN flanged versions. Other versions may have slightly different values.

** As standard, in separators manufactured with EN 1092-1 flanges, the drain connection is female threaded ISO 7 Rp. In models with ASME B16.5 flanges, this connection is female threaded NPT. Alternatively, EN 1092-1 or ASME B16.5 flanged drain connection can be supplied (ASME in the same class as main connections).

*** Standard PN 16 DN 65 flanges are supplied with 4 holes. 8 holes, according to EN 1092, on request.

Remarks: The top of the separator is supplied with a threaded connection, which size does not exceed the size of the drain connection. This connection is always supplied with a threaded socket. It can be used for air venting or sensing pipe connection.

MATERIALS	
DESIGNATION	MATERIAL
Body	ASTM A312 TP 316L
Head	ASTM A403 WP 316L
Inlet / Outlet pipe	ASTM A312 TP 316L
EN flange	ASTM A182; AISI 316/316L
ASME flange	ASTM A182; AISI 316/316L
Socket	AISI 304 / 1.4301; AISI 316 / 1.4401
Internal	ASTM A479/A276; AISI 316/316L

FLANGE CONNECTIONS			
RATING	SIZE	EN STANDARD	ASME STANDARD
PN 16	* DN 15 to 50	EN 1092-1 PN 40	ASME B16.5 Class 150
PN 16	DN 65 to 300	EN 1092-1 PN 16	ASME B16.5 Class 150
PN 40	DN 15 to 300	EN 1092-1 PN 40	ASME B16.5 Class 300

* Flanges EN 1092-1 PN 16 and PN 40, from DN 15 to DN 50, have the same number and size of holes.